

# PROVE™ PRO24

Indoor/Outdoor 12 to 24V DC Proximity Reader  
"Series 2"

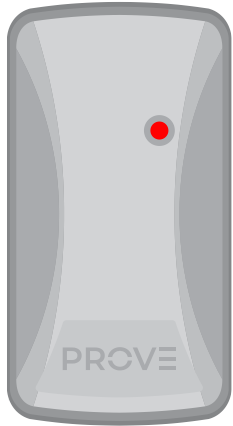

## FEATURES

- Compatible with all NIDAC Presco controllers.
- Outputs Presco and wiegand data.
- Site code read from EM cards in wiegand mode is compatible with generic EM wiegand prox readers.
- Reads HID 125kHz cards.
- Fully encapsulated unit is suitable for indoor or outdoor usage.
- Audible and visual (buzzer & LED) feedback on card read.
- 12-24V DC operation.
- 16.5mm thin surface mounting with hidden screws.
- Operating temperature range of 0°C to 70°C.
- 5 year manufacturer's warranty.

## IMPORTANT DIFFERENCES BETWEEN THE PROVE PRO24 AND PRESCO PRO2410

- Wiegand D1 is now on the white wire instead of the yellow wire
- When used in wiegand mode the site code read from EM cards is different. To make the Prove PRO24 read the same site code as the Presco PRO2410 refer to the "Wiegand EM Card Proximity Reader Options" section and set memory 060 to 121.
- Standard 26 & 37 bit HID cards can be read, other HID formats will read but the output of some cards may not match that of an HID reader.

## SPECIFICATIONS

Voltage: 8 to 28V D.C.  
 Current: 50mA max @ 8 Volts D.C.  
 35mA @ 12 Volts D.C.  
 20mA @ 24 Volts D.C.  
 Operating Temp: 0°C to 70°C.  
 Dimensions: 82.7mm x 44.7mm x 16.5mm.  
 Weight: 80 grams.  
 Output: Presco DTA or wiegand, pulse width = 50µs, pulse separation = 2ms.  
 Read Range: Up to 11cm (4 1/8").  
 Excitation Freq: 125 ± 5 KHz.  
 Wiring Distance: PRO24 to Presco PAC Controller = 1Km using unshielded cable, 100Ω max. return resistance on DTA line. To achieve distances greater than 100m the PRO24 may require a separate local power supply depending upon the thickness of the cable used.

PRO24 to wiegand controller, shielded cable must be used.

Wire Gauge	Distance	Wire Gauge	Distance
22 AWG	150m (490 ft)	26 AWG	60m (195 ft)
24 AWG	100m (330 ft)	28 AWG	40m (130 ft)

## WIRES

There are 8 wires for the PRO24, not all will be needed for each installation. The unused wires should always be terminated and left unconnected.

Black	0V (Ground).
Red	+12V D.C.
White	DTA (Presco data line) or D1 (Wiegand Data 1).
Green	D0 (Wiegand Data 0).
Blue	Blue LED control wire, +3V to +14V active.
Yellow	Blue LED control wire, 0V active.
Brown	Buzzer control wire, 0V active.
Orange	Connect to 0V (black wire) on power up to enter option setting mode.
Drain	Shield (in wiegand mode connect to earth/ground at controller).

## MOUNTING

Use the supplied mounting template to mark the cable entry and two mounting holes. **Note** that the cable entry to the PRO24 is in the centre.

## DIMENSION DIAGRAMS

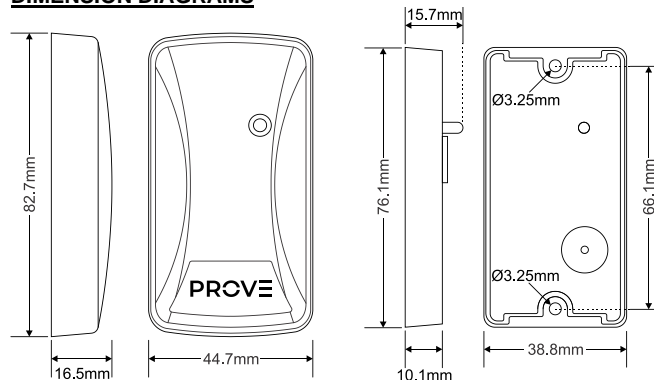

## PRO24 TO PAC1 / PAC2

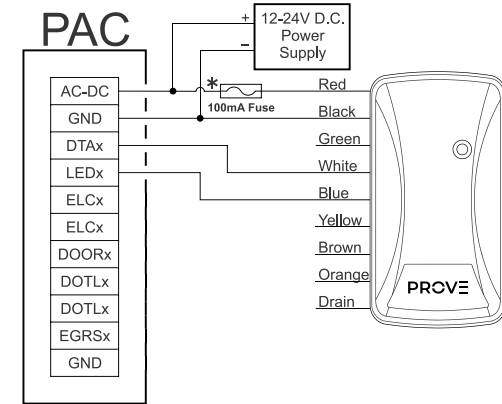

## Programming Prox cards & tags into a PAC controller

To program a proximity card or tag into a PAC controller follow the same steps as shown in the controller manual for programming a new user code. When it comes to the stage to enter the user code simply present the card or tag to the PRO24 that is connected to the same input as the programming keypad, or alternatively enter the 9 digit code for the proximity card, note that this code may contain star (\*) and hash (#) symbols and leading zeroes (0) do need to be entered.

## PAC1 Programming Example

This example uses a PAC1 controller, programming a momentary operation proximity card or tag into memory location 001.

1. Put the PAC1 into program mode using the management code or button on the PAC1.
2. Using the Prove keypad connected to the PAC1, open the memory location to store the Prox card in → 001 1 E
3. Present the proximity card or tag to the PRO24.
4. Take the PAC1 controller out of program mode.

## PRO24 TO WIEGAND CONTROLLER

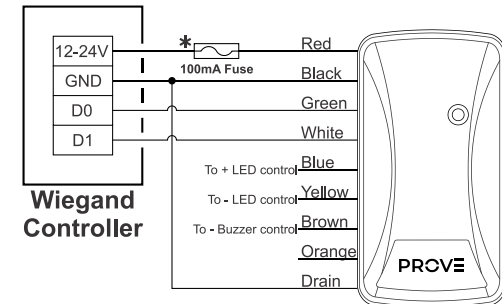

Use a positive signal (2.5 to 28V) from the controller on the Blue wire to change the LED colour to blue.

Use a negative signal (0 to 2V) from the controller on the Yellow wire to change the LED colour to blue.

Use a negative signal (0 to 2V) from the controller on the Brown wire to sound the buzzer.

\* If the controller does not provide a fused output for readers, use a 100mA inline fuse to protect the power supply from short circuiting if PRO24 wires are tampered with.

## PRO24 OPTIONS

There are several options that can be set to alter the way in which the PRO24 behaves. These options fall into the 3 categories of General, Presco and Wiegand EM Card Proximity Reader, all of these are explained below.

### General Options

These options set the functionality of the PRO24 independent of whether it is in wiegand or Presco mode.

Memory	Function	Default
005	Force Presco or wiegand mode <sup>(1)</sup>	255

#### (1) - Force Presco or wiegand mode [Memory 005]

101 = Always in Presco mode.

202 = Always in wiegand mode.

All other values = Mode auto detected using white wire.

### Presco Options

These options set how the PRO24 operates when in Presco mode. It is unlikely that these options will need to be changed.

Memory	Function	Default
011	Process received DTA characters <sup>(2)</sup>	255
012	Presco proximity reader output format (standard PAC format or KC compatible) <sup>(3)</sup>	255

#### (3) - Process received DTA characters [Memory 011]

101 = Ignore all received DTA characters (PRO24 will not give beeps, warble, etc. after card is presented).

All other values = PRO24 will make beeps, warble, etc. for DTA characters received reading a card.

#### (3) - Presco proximity reader output format (standard PAC format or KC compatible) [Memory 012]

101 = Presco output from the proximity reader is 7 digit KC compatible as per a PIM wiegand to Presco conversion (only works for 26 bit wiegand cards).

202 = Presco output from the proximity reader is 7 digit KC compatible using the lowest 7 digits of the 9 digit Presco PAC code.

All other values = Presco output from RFID is standard 9 digit PAC format.

### Wiegand EM Card Proximity Reader Options

These options set the format of the wiegand data sent by the PRO24 when it is in wiegand mode and an EM RFID card or tag is being read.

Memory	Function	Default
060	26 bit wiegand EM card site code byte to use <sup>(4)</sup>	255
061	EM card custom wiegand format <sup>(5)</sup>	255
062	Number of bits in EM card site code <sup>(6)</sup>	8
063	Number of bits in EM card user code <sup>(6)</sup>	16
064	Number of bits for EM card start parity calculation <sup>(7)</sup>	255
065	Number of bits for EM card end parity calculation <sup>(7)</sup>	255
066	EM card parity polarity <sup>(8)</sup>	2
067	Data start bit from EM card for site code <sup>(9)</sup>	1
068	Data start bit from EM card for user code <sup>(9)</sup>	25

#### (4) - 26 bit wiegand EM card site code byte to use [Memory 060]

121 = Presco reader site code byte used.

202 = Alternate site code byte 2 used.

All other values = Generic EM reader compatible site code byte used.

#### (5) - EM card custom wiegand format [Memory 061]

101 = 34 bit wiegand (16 bit site code, 16 bit user code, even start & odd end parity bits for 16 data bits each) using Presco data.

121 = 34 bit wiegand as above using alternate site code data bytes.

202 = Custom wiegand format as defined by memories 62 to 68.

All other values = Standard 26 bit wiegand.

#### (6) - Number of bits in EM card site/ user code [Memories 062 & 063]

A maximum of 40 data bits can be set as a sum of these 2 memories. If the sum exceeds 40 then the number of site code bits will be automatically reduced.

#### (7) - Number of bits for parity calculation [Memories 064 & 065]

Number of bits for parity calculation (0 = no parity bit, if the value is greater than the total number of wiegand data bits (site code + user code bits) then it will use half the total number of bits, for an odd number of bits the end parity will use 1 more bit).

#### (8) - Parity polarity [Memory 066]

0 = Start parity is Even, End parity is Even.

1 = Start parity is Odd, End parity is Even.

2 = Start parity is Even, End parity is Odd (Default).

3 = Start parity is Odd, End parity is Odd.

#### (9) - Data start bit from EM card [Memories 067 & 068]

There are 40 bits of data in an EM card organised as D00-D03, D10-D13, D20-D23, D30-D33, D40-D43, D50-D53, D60-D63, D70-D73, D80-D83 and D90-D93. Bit D00 is referred to as bit 1 for this memory and bit D93 as bit 40.

Ensure that when setting the start bit that there are enough bits after the start bit for the number of bits set for the site or user code data.

### SETTING THE OPTIONS VIA A PROVE KEYPAD

To set any of the above options a Prove keypad is required to be connected to the PRO24, as per the diagram below, and the PRO24 needs to be placed into option setting mode, this is done by following the steps below:

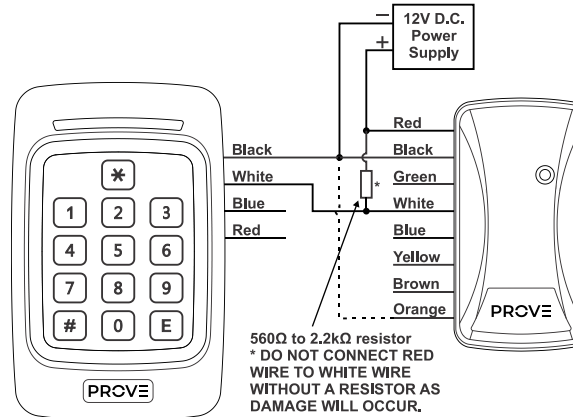

1. Remove power from the PRO24.
2. Connect the PRO24 to a PSK2 (or other Prove keypad) as per the above diagram. (If using a Prove keypad that requires external power remember to connect the red wire to +12V DC.)
3. Connect the Orange wire to 0V.
4. Reapply power.
5. Once the LED starts to double flash blue you are in option setting mode.
6. Disconnect the Orange wire.
7. The PRO24 will remain in option setting mode for 5 minutes from the last option setting sequence attempted.

#### Setting an option memory value

[\*] <3 digit Memory> <1 to 3 digit value> [E].

#### Reset all option memories to factory defaults

[\*] 9 8 7 6 5 4 E whilst in option setting mode.

#### Exit Option Setting Mode

[\*] 9 9 9 E or wait 5 minutes after last option setting attempt.

**NOTE:** Remember to disconnect the orange wire from 0V so that the PSC2 will not start up in option setting mode after a power cycle.

## WARRANTY

NIDAC Pty Ltd will repair or replace this product if proven to be faulty (excluding accidental or malicious damage) under the 5 year warranty offered from the date of purchase.

As NIDAC Pty Ltd or its agents do not perform the final installation, inspection or training in the use of this product, they cannot be held liable for injury, loss or damage directly or consequentially arising from the use or misuse of this product.

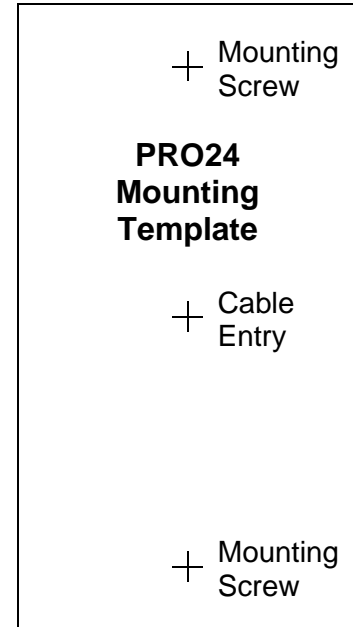

Designed and manufactured by

**NIDAC Pty Ltd**  
2 Cromwell Street  
Burwood Victoria  
Australia 3125

+61 3 9808 6244  
www.nidac.com  
sales@nidac.com

